

WATER METER REQUEST PERMIT

TOWN OF STONY PLAIN
Information Package for Home
Builders and Contractors



Information Package for Home Builders and Contractors

Water Meter Installation Requirements effective January 2021

This information package states the requirements expected by Stony Plain for every water meter installation within the Town's jurisdiction.

Water meters are important instruments used by Stony Plain to track water consumption; and charge an accurate rate of water usage. Water meter installation is required during the construction phase and prior to occupancy of the building.

A Water Meter Request Permit must be completed and submitted to Stony Plain Utilities via email to publicworks@stonyplain.com for approval prior to booking any appointment.

This can be submitted using the online form on the Town website at <https://forms.stonyplain.com/Public-Works/Water-Meter-Request-Form>

Documents referred to in this guide:

- Flow chart for Water Meter Request Process
- Water Meter Request Permit Application (online)
- Stony Plain's Water Meter Setting Standards and Guidelines (online)
- Notice to Contractors for 3/4" water meter spacing for residential homes

Installation Requirements:

A building is ready for a new water meter installation when:

1. The service line has passed all necessary tests and procedures according to Town of Stony Plain new water line commissioning guidelines, for commercial, industrial and/or multi-family installs.
2. The service line has been flushed and free of any sediment or rocks.
3. The building is heated to prevent freezing of water lines and the water meter.
4. Water is turned on to the meter setting so the water meter can be tested for leaks after installation.
5. The water meter setting meets Stony Plain's Water Meter Setting Standards and Guidelines.
 - a. Refer to Stony Plain's current Water Meter Setting Standard Drawings and spacing on our website.



Booking an appointment for water meter installation:

1. **For commercial, industrial, and multi-family installs:** The Water Meter Request Permit must be completed and submitted to Stony Plain Utilities, no later than thirty (30) business days prior to occupancy date; to allow for water meter delivery from supplier. Reminder: A water meter should be installed prior to occupancy.
2. **For single family residential, condominiums and row/townhouse installs:** The Water Meter Request Permit must be completed and submitted to Stony Plain Utilities no later than fifteen (15) business days before expected occupancy date.
3. Stony Plain Utilities are available for water meter installations 9:00 am-3:45 pm Monday-Friday.
4. If a plumber has installed the water meter 1.5" (40mm) or larger, an appointment needs to be setup with Stony Plain Utilities so the water meter and bypass can be secured and tested. Public works does not install water meters bigger than 1.5" in size. This needs to be completed by a certified plumber.
5. Stony Plain Utilities will need access to the building. If the building is locked please provide a builder's key, lockbox code, garage code or have an adult available to meet the Stony Plain Operator at the site of the installation.
6. If any of Stony Plain requirements are not met, the operator will refuse to install the water meter. If this occurs the builder will need to make another appointment and expect a charge for each subsequent visit by a Stony Plain Operator.



NOTICE TO CONTRACTORS

WATER METER SPACING FOR RESIDENTIAL HOMES (3/4" METER)

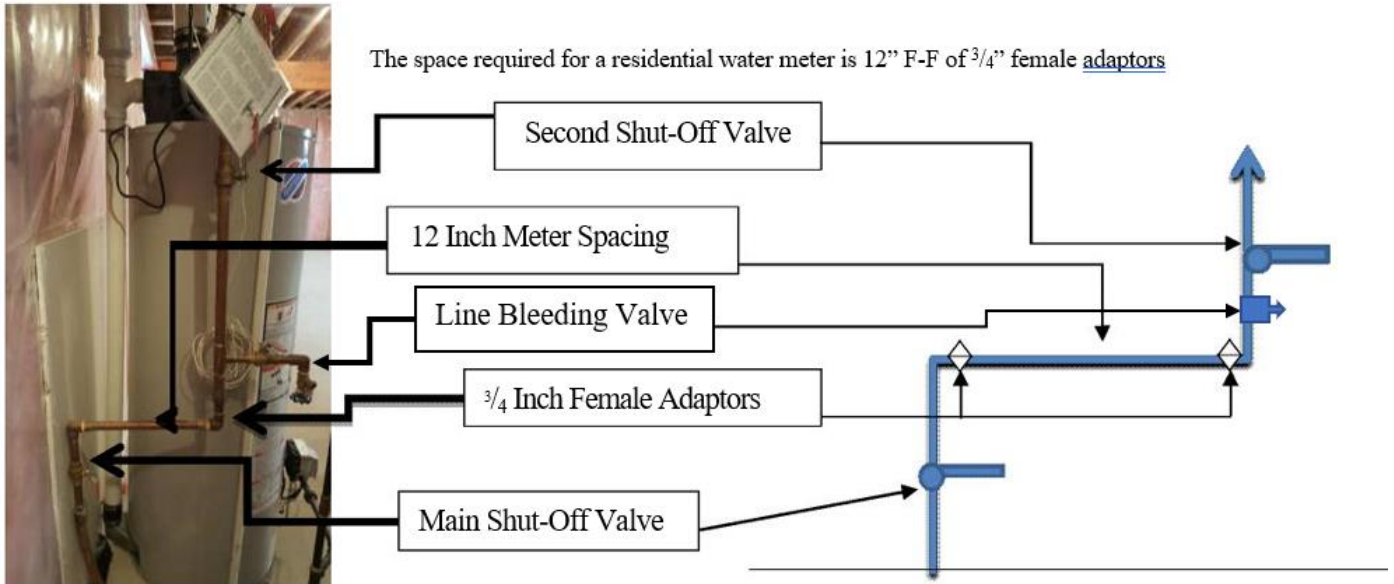

Remote Read Provisions:

A **22-gauge FT4-4 conductor wire** must be run to the outside of the house. The location of the wire is to be near the front corner of the driveway side of the building about 1 foot (12 inches) in from the corner and 4-5 feet (48-60 inches) above final grade. **Telephone wire is not acceptable.** Inside, the wire **MUST BE** terminated and visible close to the water meter location.

CC Valves:

You must ensure these valves are protected during construction. This is **YOUR** responsibility. The repair of damaged tops will be at the contractors expense. The valve box extension **MUST BE** set to final grade before concrete is poured or landscaping takes place.

Note: Homeowners, please ensure that your contractor is aware of the specifications set by the Town of Stony Plain. Failure to comply will result in fees and charges billed to the homeowners/builders or general contractors. There will be **NO** exceptions to these construction practices. Should the Town be required to make a second call to the home, business charges will apply in the amount of \$61.75.

NOTE: For all commercial or industrial installs see standards & guidelines figures on the Town website.
<https://www.stonyplain.com/en/live/water-meters.aspx>

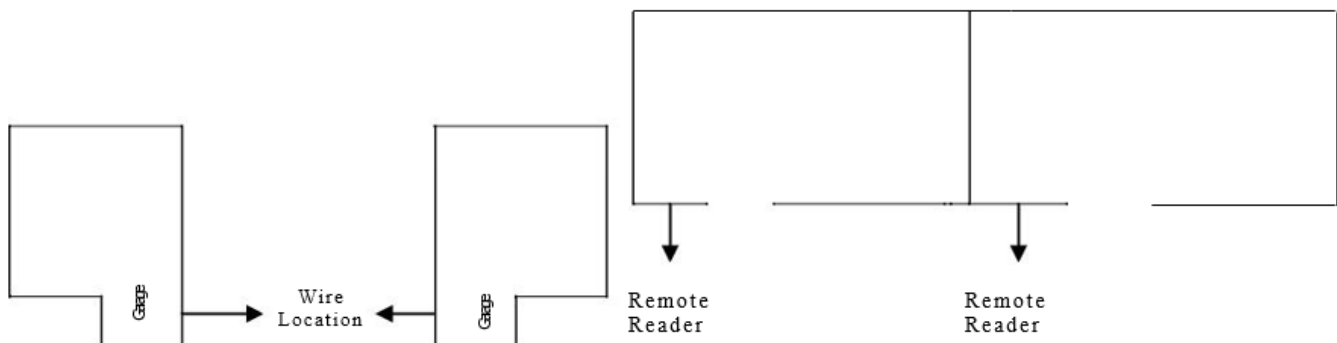

**** For all condominiums, the wire for the remote reader MUST BE located on the front of the units/home. ****

WATER METER REQUEST FLOW

