



Deck Development Permit Checklist

Information Package for Development & Building Permit Applications

A Building Permit is required for decks over 2' from the walking surface to grade at any point along the outer edge. The information indicated on this sheet is the minimum that is required for a building permit application. Please complete this form as best as possible and attach it to the building permit application.

SUBMIT WITH APPLICATION FORM

Required information for all residential alterations and additions permit applications:

- Complete and signed application form
- Landowner consent (if applicant is not the registered owner)

- Site plan
- Floor plan
- Cross-section
- Type of Foundation
 - Steel (screw) pilings – Stamped engineered detail required
 - Concrete pilings – Stamped engineered detail required
 - Pad & pier – Post must be connected to the pad to avoid from uplift. Footing pads below grade required inspection prior to backfill
 - Surface mounted – Deck piers mounted on sidewalk blocks with a gravel base *see sample diagram for requirements*

- Payment of application fees

Contact us: Town of Stony Plain • 4905 51 Avenue • Stony Plain, Alberta T7Z 1Y1 •
Phone: (780) 963-8598 • Email: planning@stonyplain.com • Website: www.stonyplain.com
Updated: January 23, 2024



Deck Building Permit Checklist

Residential - Accessory Development

(Decks, additions, accessory buildings, etc.)

Applicants must complete the checklist(s) below to accompany a development permit application for it to be able to be deemed complete for acceptance and processing by the Town of Stony Plain.

Please check each item included within your package.

SUBMIT WITH APPLICATION FORM

Required information for all change of use development permit applications:

- Complete and signed application form
- Current certificate(s) of title
- Landowner consent (if applicant is not the registered landowner)
- Site plan (2 copies) showing the following:
 - Site area
 - Location of registered easements/rights of way
 - Existing structures
 - Setbacks
 - Elevations
- Payment of application fees

Residential Deck Permit Requirements

Alberta Building Code Information Sheets

GENERAL CONDITIONS:

All municipal zoning and development requirements must be rectified.

All work, materials and construction must comply with the National Building Code – 2019 Alberta Edition.

A set of drawings must be available at the jobsite for inspection purposes.

Site Plan

Indicate the dimensions of the deck and the distances from the deck to the property lines and to any existing buildings on the site.

Floor Plan

Show view of deck from above, including depth, width, joist direction, joist size and on center spacing, joist span, length of joist cantilever, location of posts, distance between posts, beam cantilever, beam size of member and number of members. Create your own drawing by using the enclosed Deck Floor Plan Illustration as a guide or by filling in the blanks.

Cross-section

Show view of deck from the side, including the deck height at the highest location, size of posts, height of guardrails, foundation type, depth of foundation, footing size and thickness of footing.

Type of Foundation

- Steel (Screw) Pilings - Stamped Engineered Detail required
- Concrete Pilings - Stamped Engineered Detail required
- Pad & Post
 - Post must be connected to the pad to avoid frost uplift
 - Footing pads below grade require inspection prior to backfill
- Pad & Pier
 - Concrete piers to be poured with pad or mechanically connected
 - To be inspected prior to backfill
- Surface Mounted
 - Deck piers mounted on sidewalk blocks with a gravel base
 - See sample diagram for additional requirements

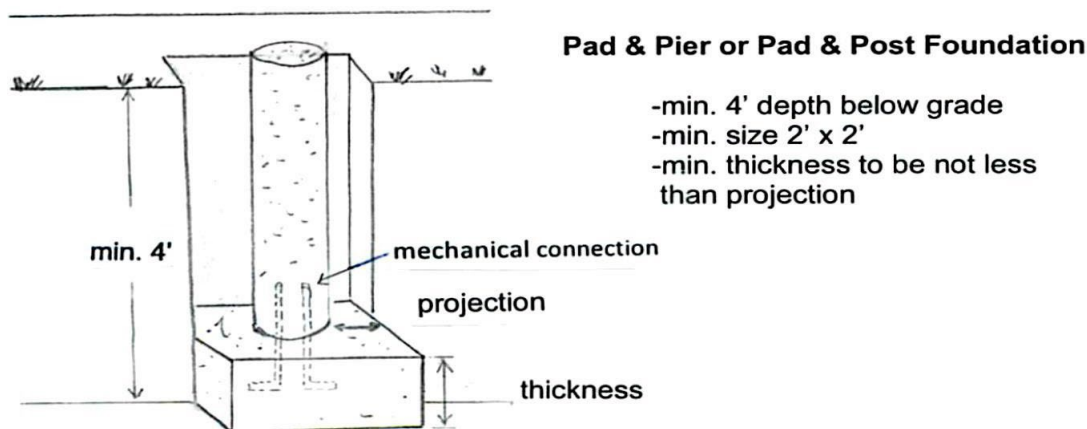

Site Plan Illustration

Show dimensions of deck, distance to property lines & distances to other buildings on the property.

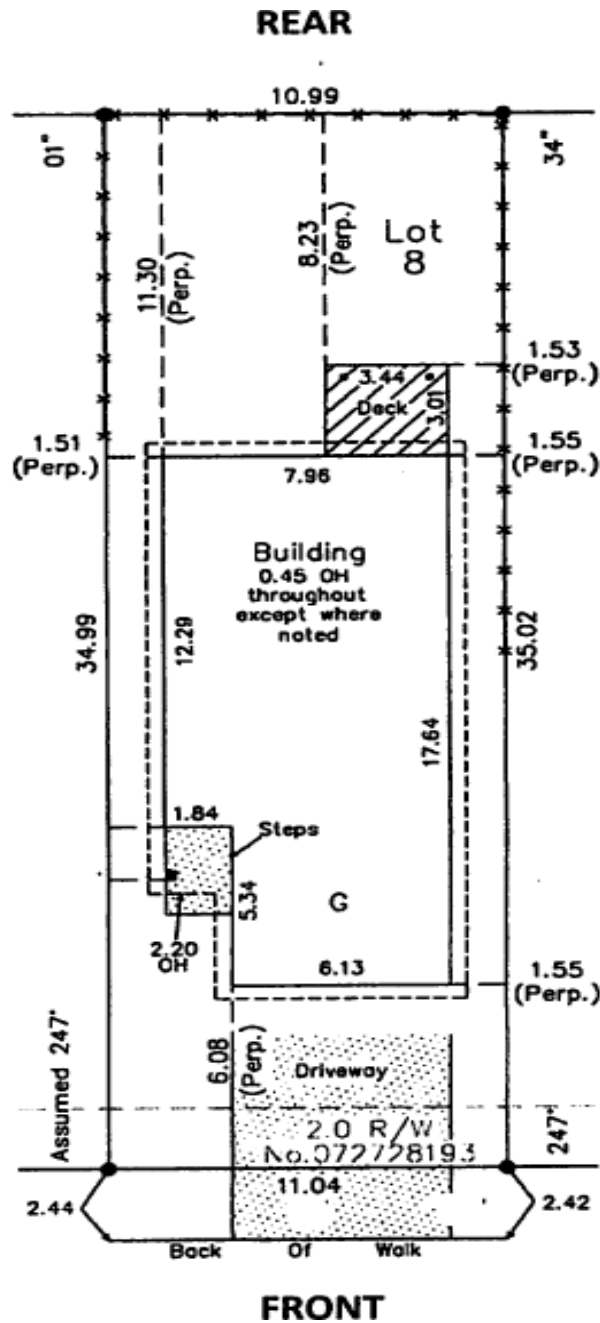

Decks over 24" to finished grade require a building and development permit.

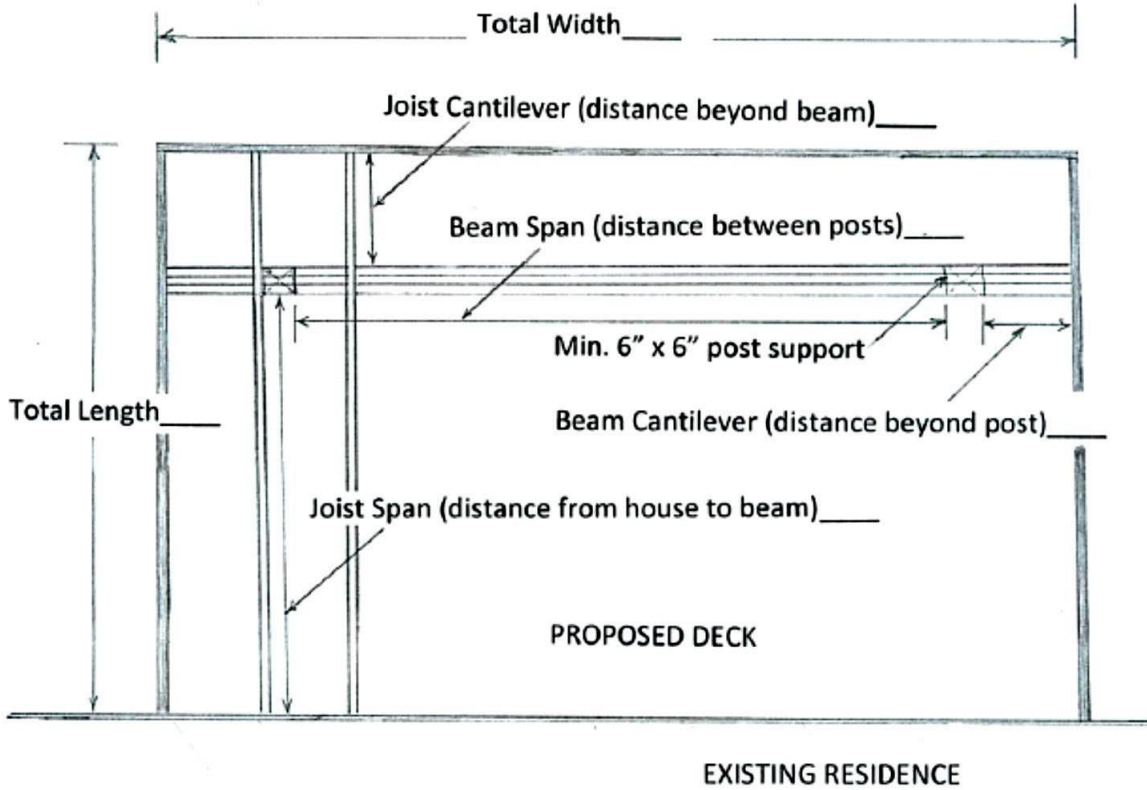

SUBMIT WITH APPLICATION FORM

Indicate size of beam members 2 x _____ and number of members _____ ply

Indicate size of floor joists 2 x _____ and on centre spacing _____

Maximum Beam Spans #1 & #2 Grade Spruce			
3 ply 2 x 8 = 9'-9"	3 ply 2 x 10 = 11'-11"	3 ply 2 x 12 = 13'-10"	
Maximum spans of #1 & #2 Spruce/Pine/Fir c/w solid blocking or bridging spaced at maximum 7' centers.			
2x6 @ 12" oc = 10'-3"	2x8 @ 12" oc = 12'-6"	2x10 @ 12" oc = 14'7"	2x12 @ 12" oc = 16'-5"
2x6 @ 16" oc = 9'-4"	2x8 @ 16" oc = 11'-9"	2x10 @ 16" oc = 13'-8"	2x12 @ 16" oc = 15'-5"
2x6 @ 24" OC = 8'-2"	2x8 @ 24" oc = 10'9"	2x10 @ 24" oc = 12'-10"	2x12 @ 24" oc = 14'-6"
Maximum cantilever of 2 x 8 joists to be 16"			
Maximum cantilever of 2 x 10 joists and larger to be 24"			

Cross-section Illustration

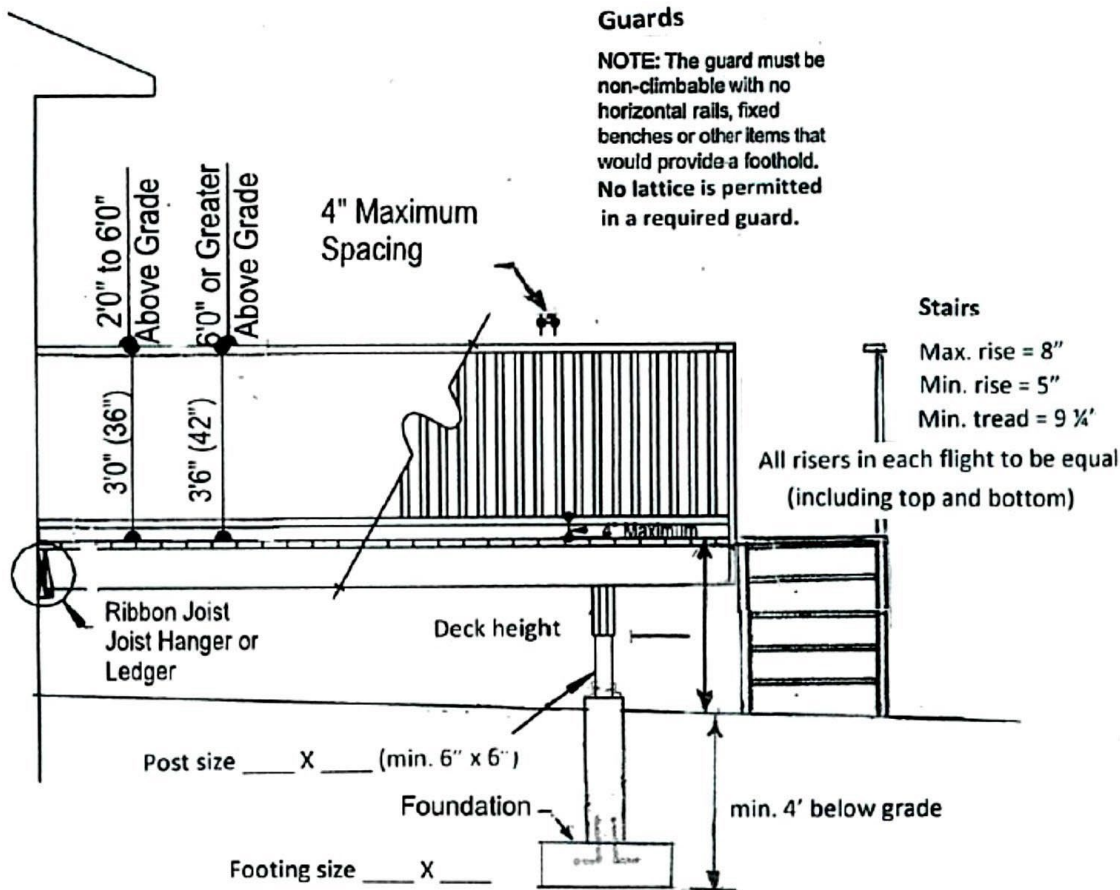

Guards

Guards are required where there is a difference of more than 24" between the walking surface and the adjacent surface. Guards are to be constructed of solid panel, safety glass, or vertical spindles with maximum 4" spaces, pony walls or adjacent house walls.

Handrails

Only one handrail is required on exterior stairs having more than 3 risers. Handrails are to be continuous (uninterrupted hand hold), graspable (maximum 2 1/2" in diameter). The minimum height shall be not less than 32" and the maximum height not more than 38". Clearance of minimum 2" is required between a handrail and the surface behind it.

Surface Mounted Decks

Surface mounted decks are permitted provided the deck:

- a) is not more than 1 storey,
- b) is not more than 55 m² (592 ft²) in area,
- c) does not have a distance from the finished ground to the underside of the joists exceeding 600 mm (2 ft),
- d) has access provided to allow for re-levelling,
- e) does not support a roof, and
- f) is not attached to another structure.

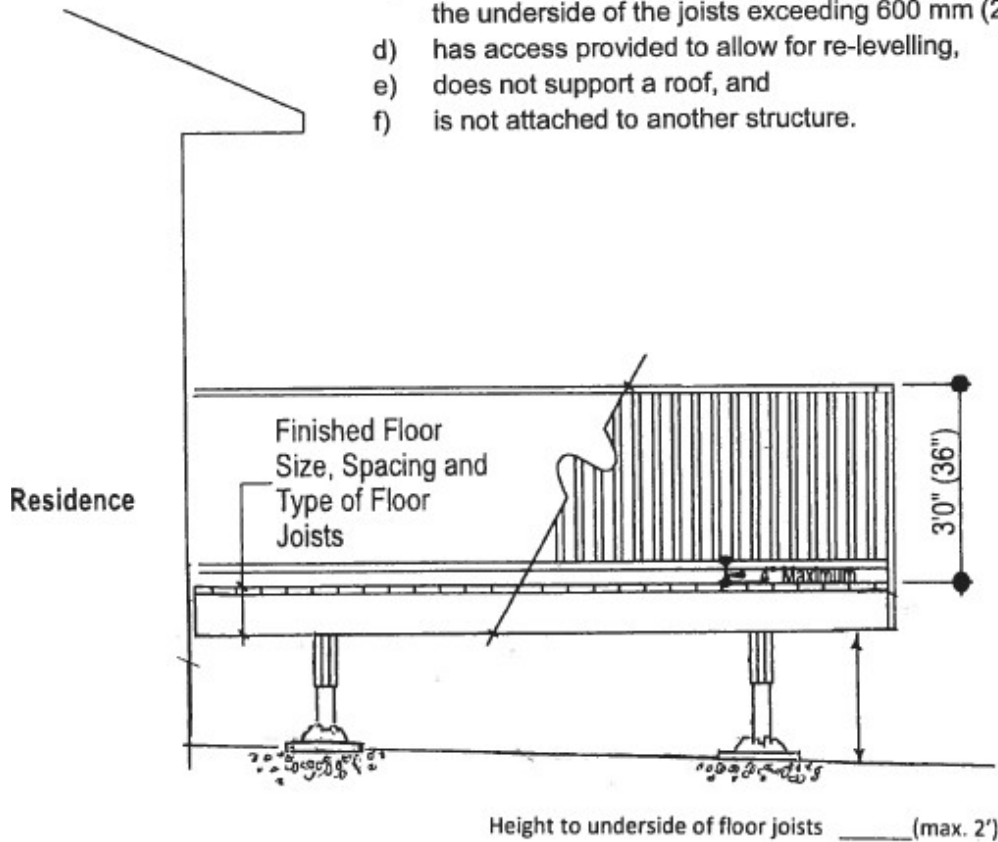



Additional Information

Application Fees

BUILDING PERMIT APPLICATION FEES	
Single family & semi-detached dwellings	
Minimum Building Permit Fee, includes any Miscellaneous Building Permit Item (in ground swimming pool, hot tub, portable pool, deck, wheelchair ramp, minor solar panel installation, HVAC installation, wood stove fireplace, temporary structure like a tent)	\$150.00
New construction & additions	\$6.00/m ²
Basement development & renovations or accessory building (attached or detached)	\$3.00/m ²
Walk-out basement development & secondary suites	\$5.00/m ²
Foundations of footing only	\$3.00/m ²
Re-inspection fee (residential)	\$100.00/hr min
Multi-family dwellings/Commercial/Industrial/Community Services & Institutional	
New construction, additions, renovations or tenant improvements	\$6.00/m ²
Basement & other finished areas (incl. parkades) or accessory buildings	\$3.00/m ²
Minor renovation (such as demising wall) or change of use	\$250.00
Re-inspection fee	\$250.00/hr min.
Miscellaneous building permit fees	
Water / sewer installation report (PW)	\$50.00
DEVELOPMENT PERMIT APPLICATION FEES	
New Construction	
Single detached & semi-detached or row housing use (includes manufactured homes)	\$200.00 /unit
Comprehensively planned, multi-family dwelling or high-density residential use	\$200.00 + \$150.00/unit
Non-residential use (including additions)	\$500.00 + \$1.00/m ²
Miscellaneous	
Other non-residential (decks, accessory building or use, demolition) or change of use	\$200.00
Other residential (decks, additions, accessory buildings, home occupations, renovations, demolitions, etc.)	\$150.00
Boulevard crossing (driveway widening)	\$100.00
Earthworks development permit or external agency applications or referrals	\$500.00
Minor sign (event, portable, fascia, etc.)	\$150.00
Major sign (billboard, freestanding, electronic message board, etc.)	\$200.00
Safety codes consultation	
Safety codes consultation service	\$150.00/hr min.
Building permit revision & extension	50% of BP fee
Penalty for beginning construction without permits	100% of BP fee
Water meter deposit - full amount charged at installation	
Single family residential	Market value
Multi-family residential	Market value
Commercial, Industrial, institutional	Market value
Bylaw applications or amendments	
New or major amendment to a statutory plan (includes municipal development plan, area structure plans or area redevelopment plan)	\$6000.00
Minor amendment to a statutory plan or new or amendment to non-statutory plan (includes land use bylaw amendment, road closure, change to reserve land, etc.)	\$4000.00
Re-submission fee or revision fee	\$1000.00



Compliance Reports	
Residential	\$150.00
Non-residential	\$250.00
Revised certificate (within six months of original compliance)	\$75.00
Rush service (completed within 3 business days)	100% of fee
Development agreements and other agreements	
Major development agreement (generally for subdivision applications)	\$5000.00
Minor development agreement (generally for development permit applications)	\$3000.00
Other agreements (easements, assignments, encroachments, etc.) or amending agreements	\$2000.00
Subdivision and condominiums	
Subdivisions or bare land condominium (includes remnant parcel and common property excludes municipal reserve and public utility lot)	\$1000.00 + \$300.00/lot or unit
Subdivision endorsement extension request (includes remnant parcel and common property excludes municipal reserve and public utility lot)	\$1000.00
Endorsement of subdivision or bare land condominium (includes remnant parcel and common property; excludes municipal reserve and public utility lot)	\$500.00 + \$300.00/lot or unit
Endorsements of traditional condominium (condominium conversions)	\$500.00 + \$40.00/unit
Re-submission/revision fee	\$1000.00
Development security deposits	
Development Security Deposit for a Major Development Permit (commercial industrial, institutional, comprehensively planned or high-density residential developments) or Earthworks	\$10,000.00
Environmental & Parcel assessment information requests	
Environmental records search request	\$200.00/per parcel
District and land use confirmation letter	\$100.00
Land title transactions	
Land Title Request (new caveat postponement or discharge of a caveat)	\$150.00 + Land title fees
Land Title Instrument Search Request (certificate of title, caveat, etc.)	Land title fees
Planning Documents (GST may be applicable)	
Land use bylaw	\$100.00
Municipal planning document (municipal development plan, area structure plan, master plan, etc.)	\$50.00
Street map or land use map	\$20.00
Refunds	
Refund information available upon request	

Frequently Asked Questions:

Why do I need a building permit?

Building permits are required to ensure the health and safety of residents and are regulated under the Safety Codes Act, Permit Regulations and the Alberta Building Code.